

4.5 Transfer Lines

4.5.1 Linac to Booster Transfer Line

The linac to booster transfer line (LTB) provides for matching of beam parameters from the exit of the linac to the booster synchrotron injection septum. For the horizontal injection scheme the LTB does not include vertical bending magnets. Matching was performed in six-dimensional phase space with coordinates $\beta_x, \beta_y, \alpha_x, \alpha_y, \eta_x$ and η'_x .

The LTB was designed taking into account the following main requirements:

- geometric matching with total bending angle sufficient for the linac to comfortably reside inside the booster synchrotron (see Fig 4.1.1 general layout);
- location of transfer line bending magnets far from booster magnets to avoid interaction between them;
- fulfill translation of beam acceptance of 2σ beam;
- long drift section to traverse the shielding wall of the linac bunker;
- sufficient free space for diagnostic and measurement instrumentation.

At the linac exit, we assume the electron beam emittances to be less than 10^{-6} m rad in both planes. The final beam parameters are defined by the optics of the booster synchrotron. The beam optical parameters at the linac exit and the booster injection point are listed in Table 4.5.1 while the schematic layout of the LTB is shown in the Fig 4.5.2.

Table 4.5.1 Beam parameters to be matched at the beginning and at the end of the LTB.

Parameter	Linac exit	Booster injection point
Energy (MeV)	100	100
Energy spread (r.m.s/max, %)	0.5/1.5	0.5/1.5
Horizontal beta, β_x (m)	5.2	6.7
Vertical beta, β_y (m)	5.2	4.5
Horizontal alpha, α_x (rad)	0	-1.1
Vertical alpha, α_y (rad)	0	1.1
Horizontal dispersion, η_x (m)	0	0
Dispersion slope, η'_x (rad)	0	-0.044

The optical functions of the LTB were calculated by the accelerator code OPA [1] and are presented in the Fig 4.5.1. The matching procedure has been performed by the code COMFORT [2]. The linac is followed by the quadrupole triplet, which provides beam focusing before the beam enters the first dipole magnet. The dipole magnet will guide the beam to the booster by a 15° deflection or to the beam diagnostic line for a measurement the beam energy spread and the beam dump. Two quadrupole triplets are located in the drift section between two bends, one in the linac bunker and the other in the ring tunnel. They provide the long drift section for beam transport through the shielding wall at low beta as well as performing the phase-space matching to the booster acceptance.

The second dipole magnet deflects the beam by 7° to the booster leaving 14° for the injection septum. Finally, the injection kicker deflects the beam by 10.6 mrad into the booster orbit.

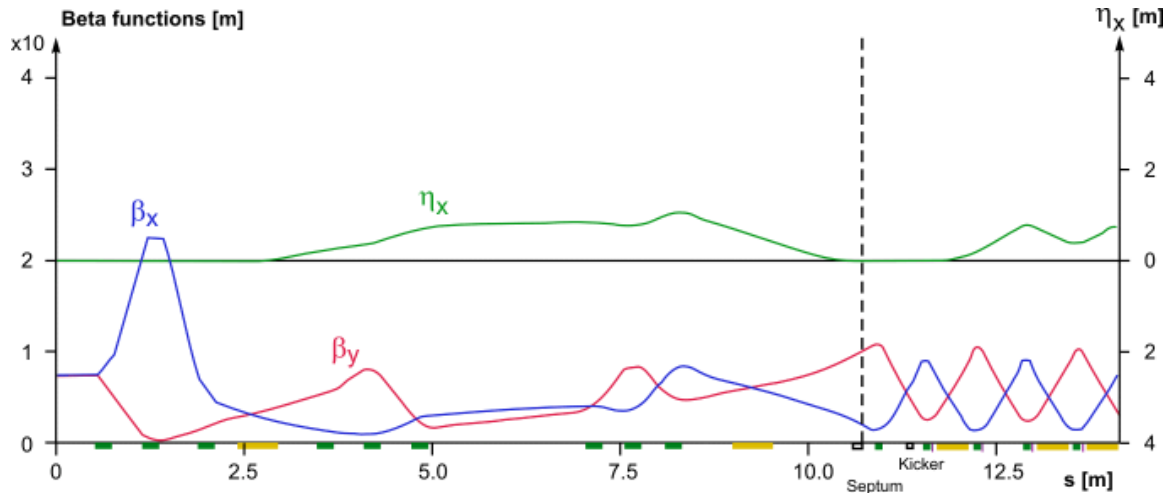

Fig 4.5.1 Optic functions of the linac to booster transfer line.

Fig 4.5.1 show the beta functions and dispersion along the transfer line, starting from exit of the linac and ending in the center of the first regular cell of the booster lattice. The flexibility of transfer line also allows matching to the booster with different initial conditions. Fig 4.5.2 shows the schematic layout of the transfer line with indications for positions of diagnostic and control instrumentation. The magnet parameters obtained from optical calculations are listed in the Table 4.5.2. The integrated current transformers at the beginning and the end of LTB will be used for monitoring transmission through the beam line, while the screen monitors will be used for visualizing the transverse dimensions of the beam. In addition, three BPM's can be used for online monitoring of beam positions. The momentum spread through the LTB can be limited by using the horizontal scraper acting together with the first bending magnet as an energy filter.

The transfer line includes also horizontal and vertical steering dipoles for small adjustments of the beam direction in the LTB and for final alignment into the booster synchrotron.

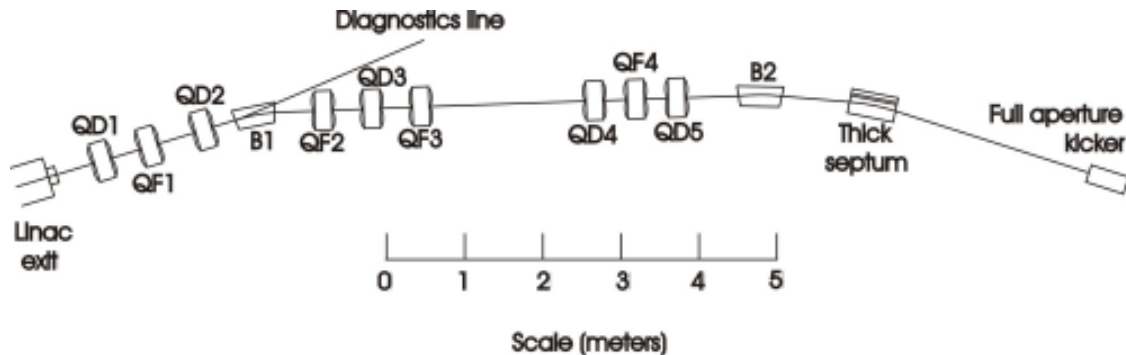

Fig 4.5.2 Schematic layout of the linac to booster transfer line.

Table 4.5.2 Linac to booster transfer line dipole parameters

Parameter	Dipole
Number of dipoles	2
Magnetic length (m)	0.5
Full gap height (mm)	30
Bending angle	$15^0; 7^0$
Max. field (T)	0.62

Table 4.5.3 Linac to booster transfer line quadrupole parameters

Parameter	Quadrupole
Number of quadrupoles	9
Magnetic length, (m)	0.2
Aperture radius, (mm)	30
Max. strength, (m^{-2})	15

For diagnostic purposes, a beam line instrumented with a scintillation screen and a Faraday cup is provided at first dipole magnet after the linac, which permits analysis of the beam from the linac, even if the booster ring is not available for injection, e.g., during booster maintenance. The beam line is equipped by BPMs, scintillators and TV cameras that permit beam control and steering through the transport line by an operator.

Magnets Power Supply. The function of the LTB transfer line is to transport the 100-MeV electron beam from the end of the linac to the injection point of the booster synchrotron and match the beam parameters with the periodic solution of the booster ring. The beam is injected at the top of the kicker pulse. The duration of the pulse is 400 ns and kicker pulse decays in 160 ns before the injected first bunch reaches the kicker magnet. Thus from the total 320 RF buckets of the booster, the linac in multi-bunch operation mode fills maximum 240 buckets. As the figure 4.5.3 shows, the BTS contains a total of nine quadrupoles, 2 bending dipoles and 9 quadrupoles.

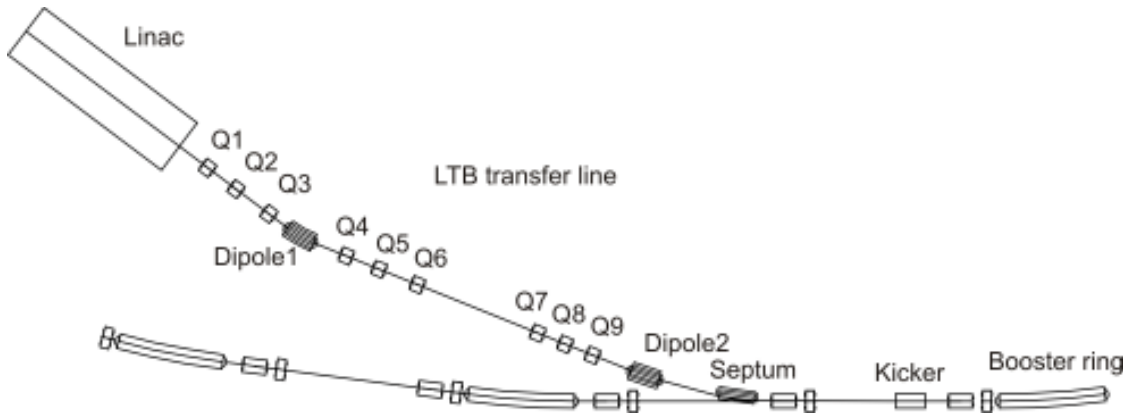

Fig. 4.5.3 Linac to booster transfer line

The LTB transfer line utilize commercially available power supply units, for all current-regulated dipole and quadrupole magnet requirements. The specifications of power supplies are given in Table 4.5.4.

Table 4.5.4 LTB transfer line magnets power supply specifications.

System	Magnet circuit	Quantity	Current (A)	Voltage (V)	Power (kW)
LTB	Dipole	2	25	30	0.75
LTB	Quadrupole	9	10	20	0.2

Two dipole magnets and nine quadrupole magnets referring to the LTB transfer line are powered individually with separate power supply units. Each dipole requires current equal to 25A, each quadrupole magnet requires current equal to 10A. Each magnet is fed individually from separate power supply unit. These units are powered from bulk power supply. The block-scheme of LTB transfer line magnets power supply system is shown in Fig. 4.5.4.

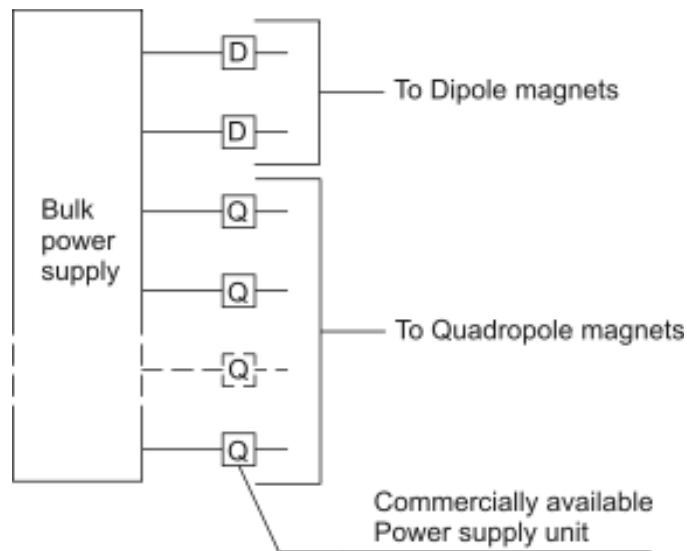

Fig. 4.5.4 Block-scheme of LTB magnets to power supply system connection.

4.5.2 Booster to Storage Ring Transfer Line

The booster to storage ring (BTS) transfer line is the final part of the injection system delivering the accelerated electron beam from the booster to the main storage ring. The BTS has to fulfill two basic requirements that are:

- Exact geometric matching of booster extraction point with the storage ring injection point.
- Optical matching of beam parameters in a six-dimensional phase space between booster extraction point and storage ring injection point.

The design of the BTS was made to include a long drift section for installation of vertically bending magnet to guide the booster beam outside of the tunnel for future possible experiments. Care was taken to also provide easy access to all elements of the transfer line and the ring by service personal. The precise connection of the exit of booster extraction region and the entrance of storage ring injection region was done using AutoCAD-2000 [1].

The 4-fold symmetry of the booster synchrotron and 16-fold symmetry of the storage ring allow various configurations on transfer line. The transfer line that connects the booster extraction straight section with the storage ring injection section has to provide the bends of the extracted beam by an angle of 45° . The total length of BTS transfer line is 27.807m. Taking into account the difference of 5° between the extraction and injection angles three dipoles were chosen for a total bending angle of 40° . The placement of the first and third dipoles was dictated by the need to stay furthest from the stored beam and to avoid conflicts with the extraction and injection magnets, respectively.

Optical matching was carried out using the code COMFORT [2]. For the two rings located in the same horizontal plane, the optical matching was performed in six-dimensional phase space by matching the Twiss parameters $\beta_x, \beta_y, \alpha_x, \alpha_y$ and the horizontal dispersion η_x, η_x' . The initial beam parameters are given from the booster periodic solution and the final beam parameters are defined from the storage ring periodic solution. These optical parameters are listed in the Table 4.5.5.

Table 4.5.5 Optical parameters at beginning and at the end of BTS.

Parameter	Initial value	Final value
Horizontal beta β_x (m)	6.4	7.89
Horizontal alpha α_x (rad)	1.107	0.0
Vertical beta β_y (m)	4.3	4.87
Vertical alpha α_y (rad)	-1.17	0.0
Horizontal dispersion η (m)	0.0	0.18
Dispersion divergence η' (rad)	-0.044	0.0

The BTS transfer line optical functions are presented in Fig.4.5.5. The energy spread of the extracted beam is at a level of 0.07%. The beam envelope along the transfer line for 1% coupling is shown in Fig. 4.5.6. The transfer line starts from the entrance to the first extraction septum magnet of the booster and ends at the exit of the last injection septum magnet of the storage ring. The maximum rms bunch size in the horizontal plane is 2 mm.

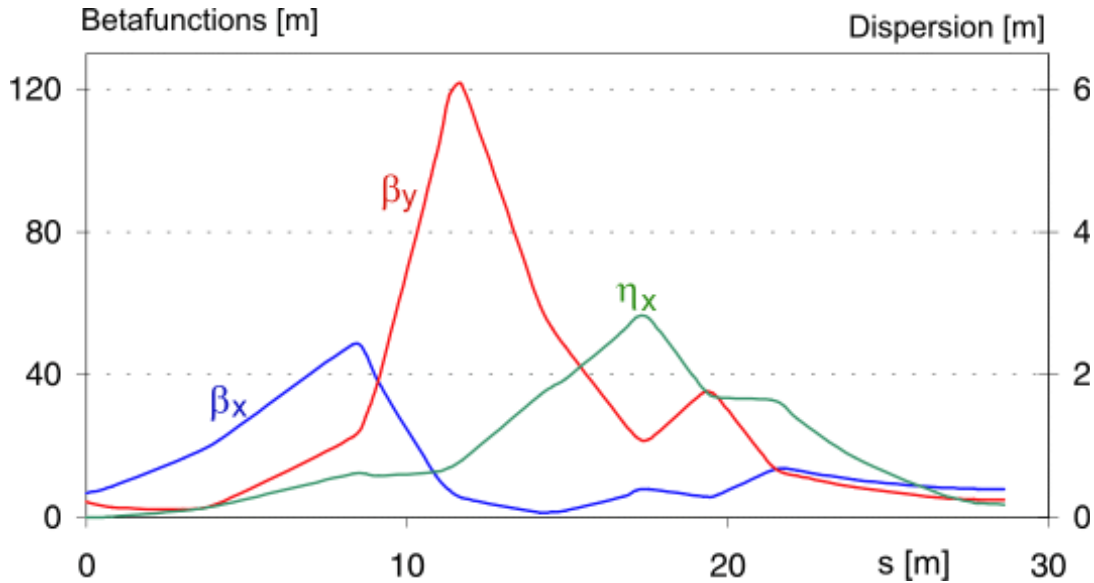

Fig. 4.5.5 Optical functions of BTS transfer line.

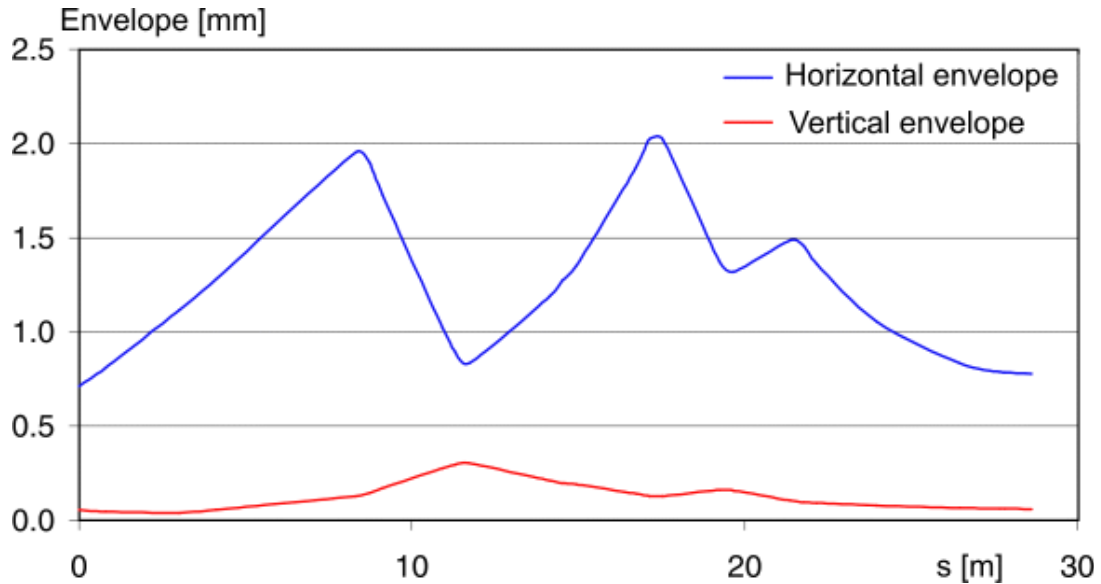

Fig. 4.5.6 The beam envelopes along the transfer line.

The strengths of the quadrupoles along the transfer line that exactly match the Twiss parameters and dispersion function of two rings are given in Table 4.5.6. The positive values correspond to defocusing quadrupoles while negative values correspond to focusing quadrupoles. Note that the focusing quadrupole Q3 has a very low strength and together with the subsequent focusing quadrupole Q4 can be used for the final adjustment of the matching providing the necessary flexibility of the transfer line.

Table 4.5.6 Strengths of transfer line quadrupoles.

Quadrupoles	Strength (m^{-2})	Gradient (T/m)
Q1	-0.764	7.64
Q2	0.759	7.59
Q3	-0.162	1.62
Q4	-0.944	9.44
Q5	0.808	8.08
Q6	-0.626	0.626

The BTS transfer line design is schematically shown in Fig.4.5.7 while the magnet main parameters are summarized in Table 4.5.7. The BTS transfer line consists of three dipoles and six quadrupoles. Each dipole magnet is designed for bending angle of 13.3° . The corresponding magnetic field is 1.29 T at 3 GeV. The maximal gradient for the quadrupole magnets is 10 T/m at 3 GeV.

To compensate for magnet misalignments, and to permit precise alignment of the beam into the storage ring injection elements four pairs of low field steering magnets are included in the BTS transfer line (not shown in the Fig.4.5.7).

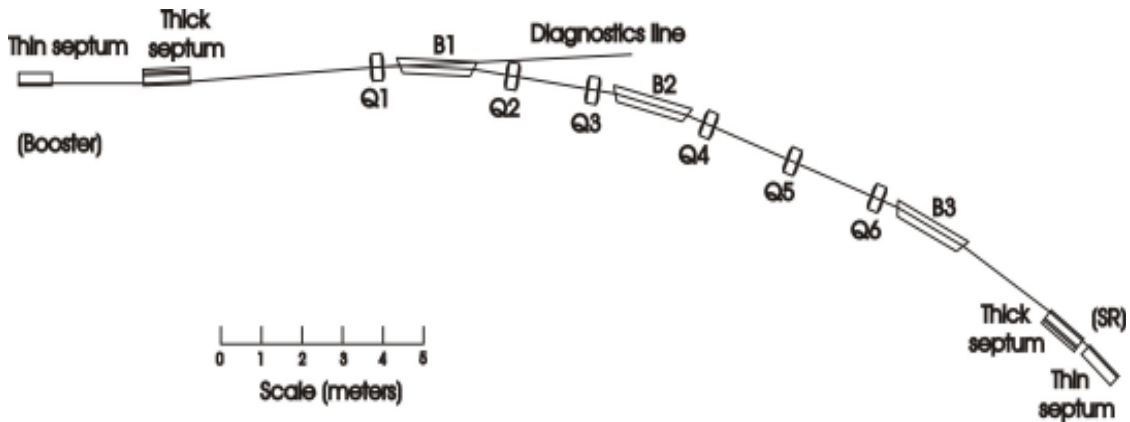

Fig. 4.5.7 Schematic layout of booster to storage ring transfer line.

The bending magnets of the BTS transfer line are of the same design and length as the booster synchrotron bending magnets but have different radius of curvature. The quadrupole magnets are also identical to the booster quadrupole magnets, but each magnet has an individual power supply.

After the first bending magnet, booster extraction diagnostics line is provided. Switching off the dipole field and allowing the beam to enter a well-shielded enclosure containing a viewing screen and a total-current monitor, a diagnostic tool can utilize the beam profile and current measurements of the beam extracted from the booster. The transfer line is equipped with corrector magnets and beam position monitors. Extensive control of the beam trajectory will be performed to provide a stable, reproducible and clean injection of the 3 GeV extracted beam into the storage ring in all three modes of facility operation: single and multi-bunch modes, top-up injection mode.

Table 4.5.7 BTS transfer line magnets main parameters

Magnet type	Nominal Value
Dipoles	
Quantity	3
Gap height (mm)	30
Effective length (m)	1.80
Dipole field (T)	1.29
Deflection angle (deg)	13.3
Quadrupoles	
Quantity	6
Aperture radius (mm)	20
Effective length (m)	0.4
Max. gradient (T/m)	12

Magnets Power Supply

The function of the BTS transfer line is to deliver the 3.0-GeV electron beam extracted from the booster synchrotron to the injection point of the storage ring.

The bending magnets of the BTS transfer line are the same design and cross section as the booster bending magnets. The quadrupole magnets are also identical to the booster synchrotron quadrupole magnets.

The design of BTS transline is shown in Fig. 4.5.8.

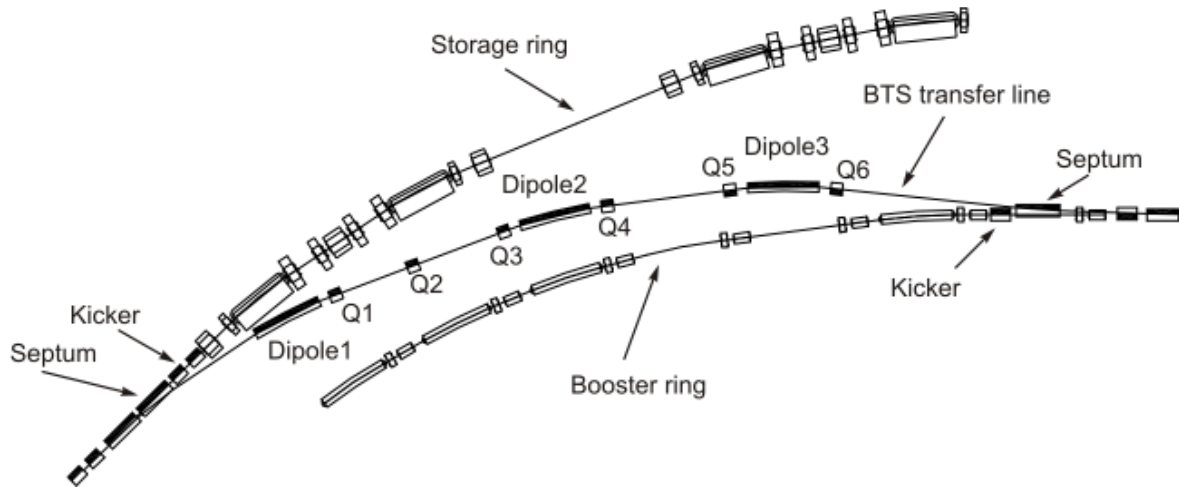

Fig. 4.5.8 BTS transfer line design

The BTS transfer line utilize commercially available power supply units, for all current-regulated dipole and quadrupole magnet requirements. The specifications of power supplies are given in Table 4.5.8.

Table 4.5.8 BTS transfer line magnets power supply specifications

System	Magnet circuit	Quantity	Current (A)	Voltage (V)	Power (kW)
BTS	Dipole	3	550	5	2.75
BTS	Quadrupole	6	100	4	0.4

Three dipole magnets and six quadrupole magnets referring to the BTS transfer line are powered individually with separate power supply units.

Each dipole requires current equal to 550A, each quadrupole magnet requires current equal to 100A. Each magnet is fed individually from separate power supply unit. These units are powered from bulk power supply. The block-scheme of BTS transfer line magnets power supply system is the same as is shown in Fig. 4.5.4.

References

- 1 <http://www3.autodesk.com/adsk/>
2. M.Lee et al, COMFORT, SLAC, Stanford.